

BASIC Flex Protect

BFP400S/BFP600S/BFP800S/BFP900S/
BFP1000S/BFP1200S/BFP1500S

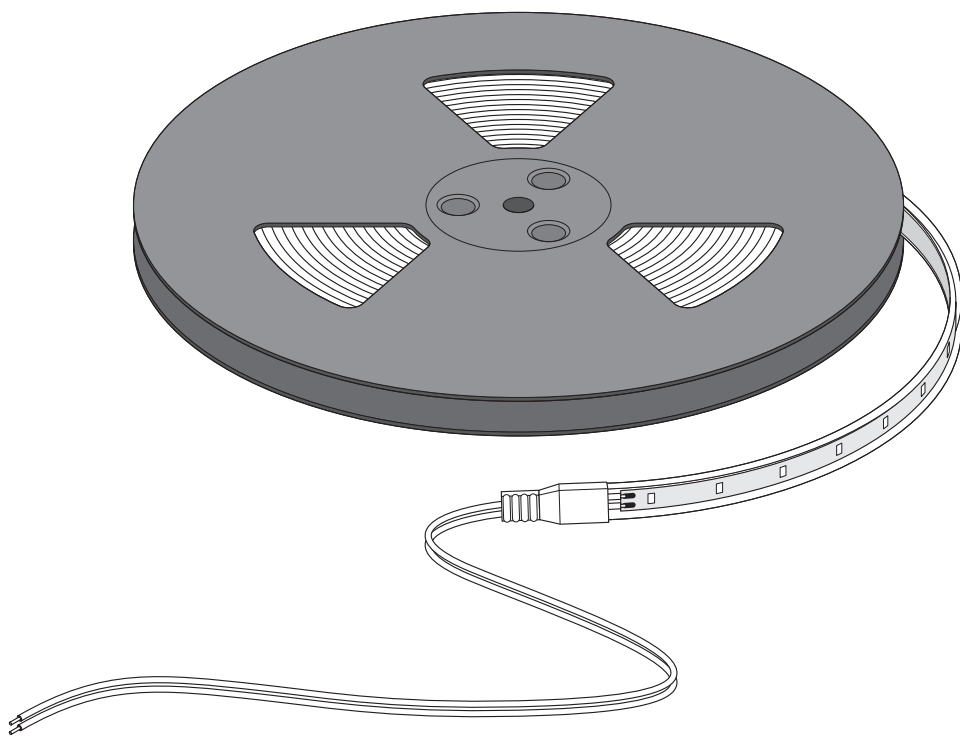

OSRAM

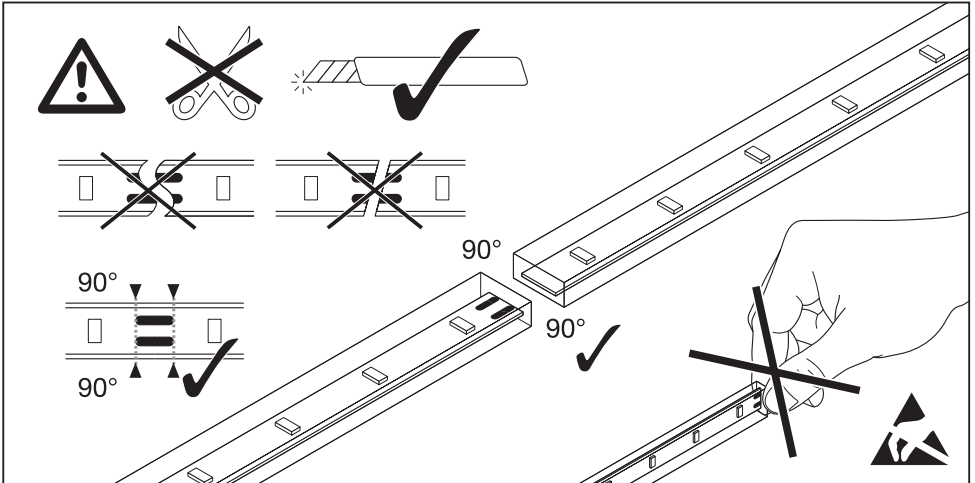
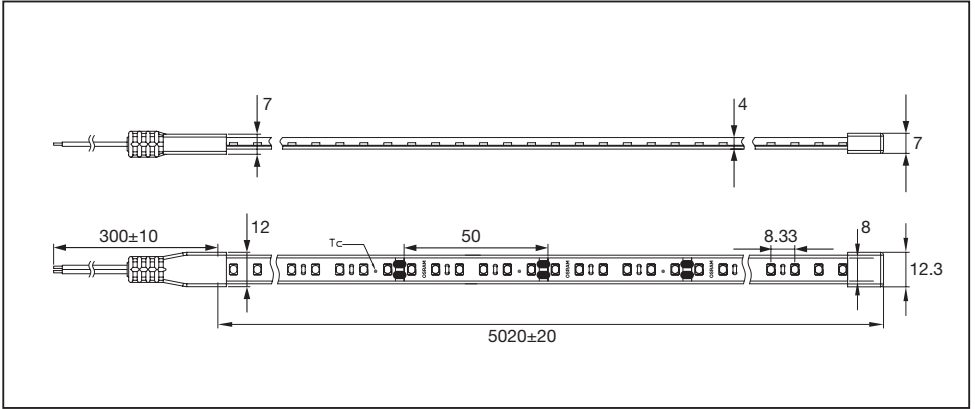

IP54

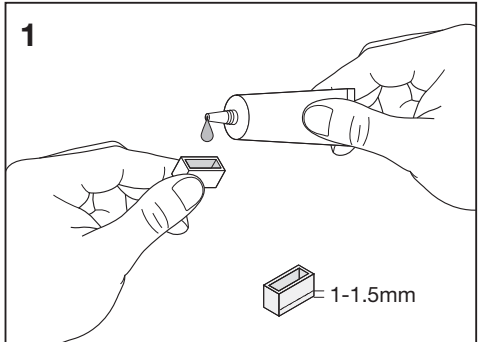
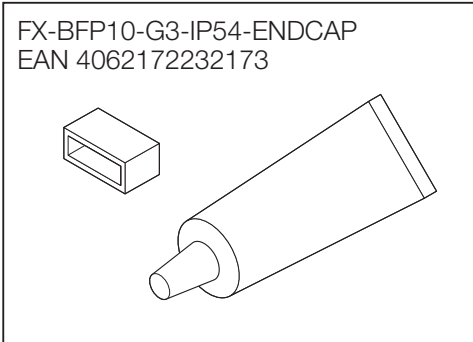

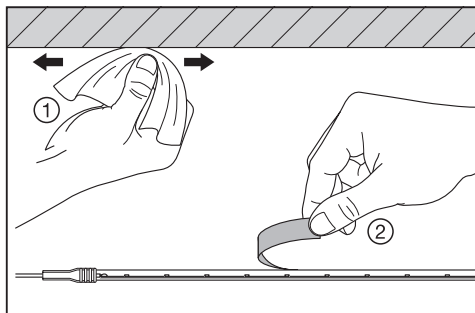
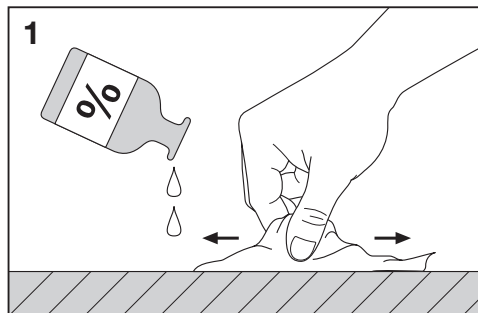
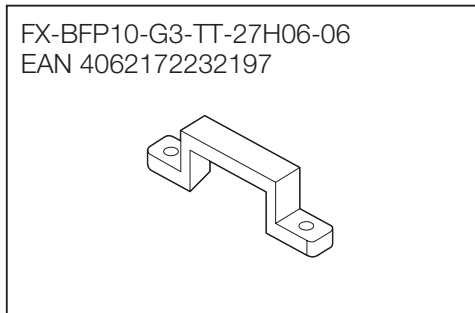
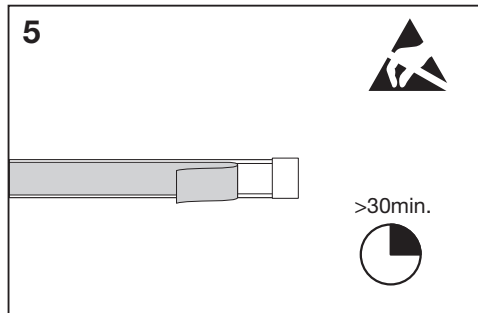
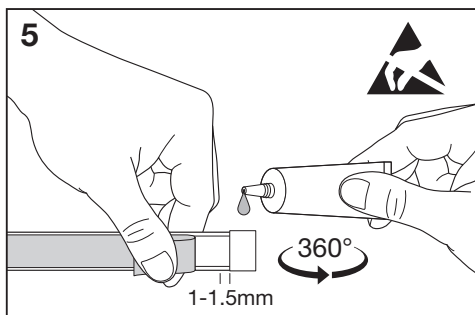
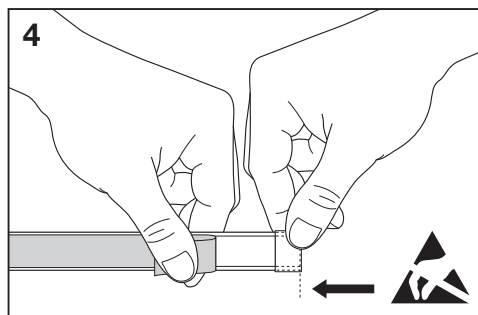
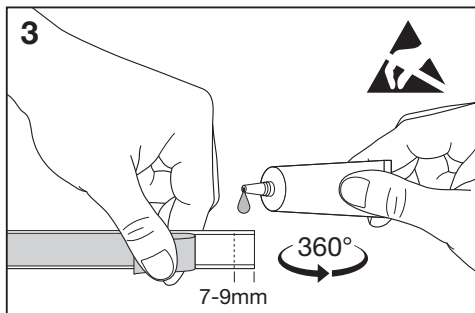
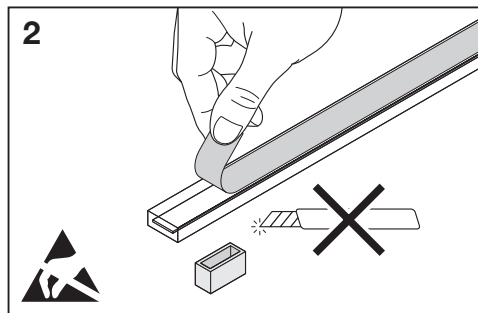

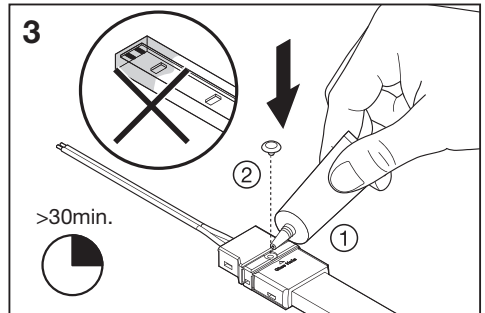
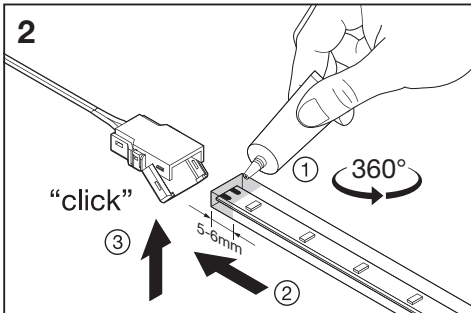
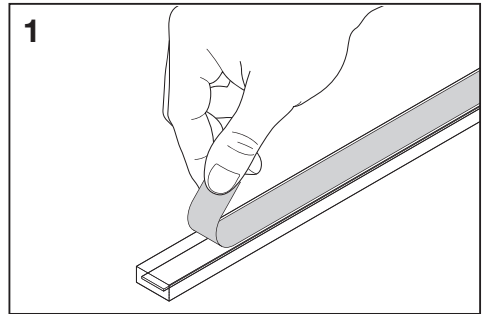
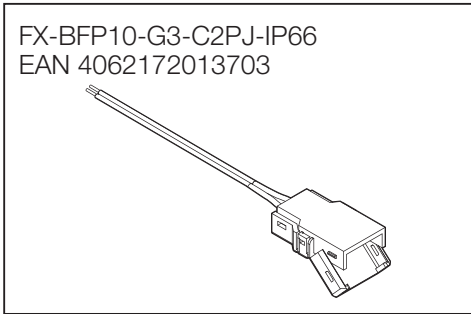
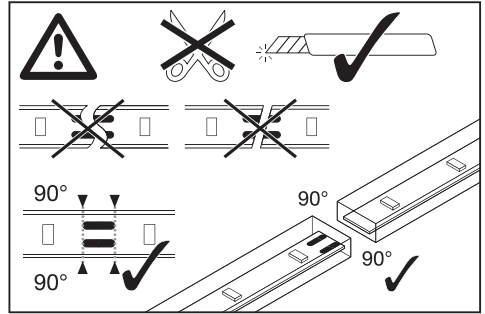
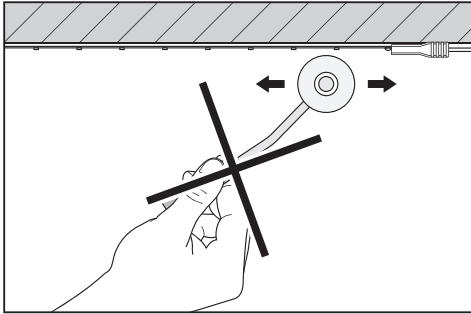
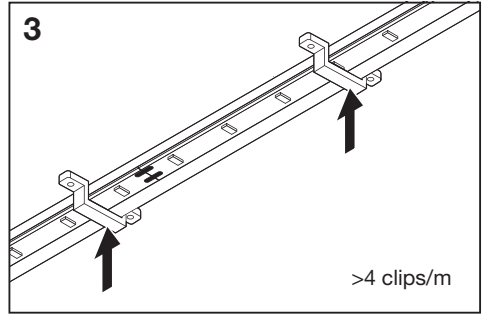
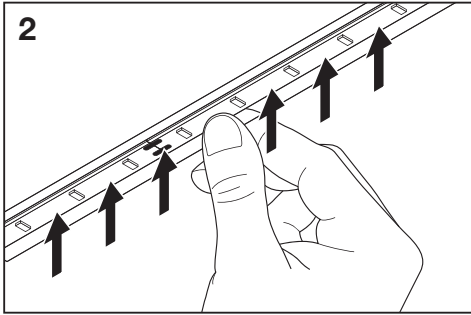

FX-BFP10-G3-C2PI-IP66
EAN 4062172013680

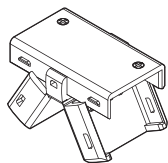

1

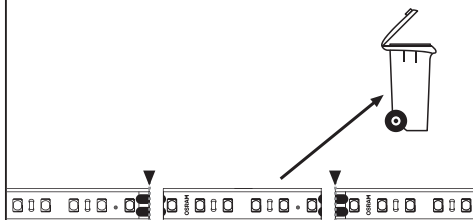

2

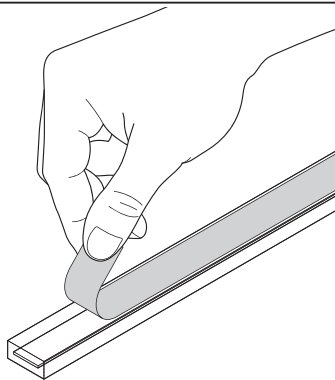

3

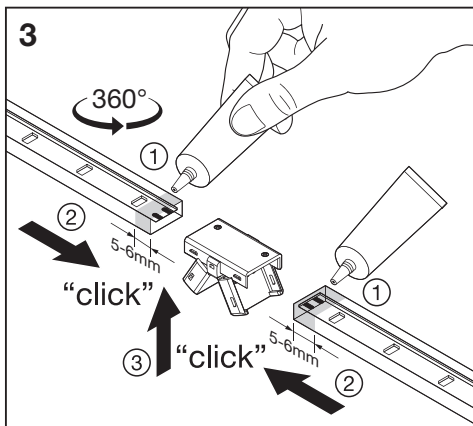

4

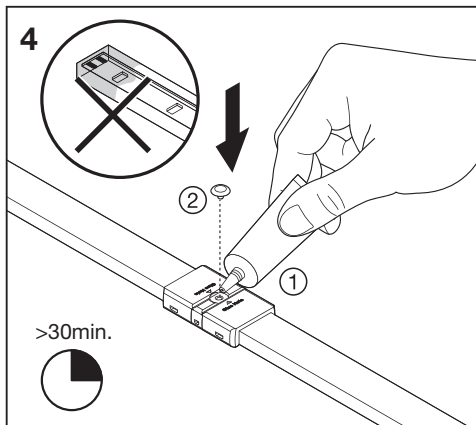

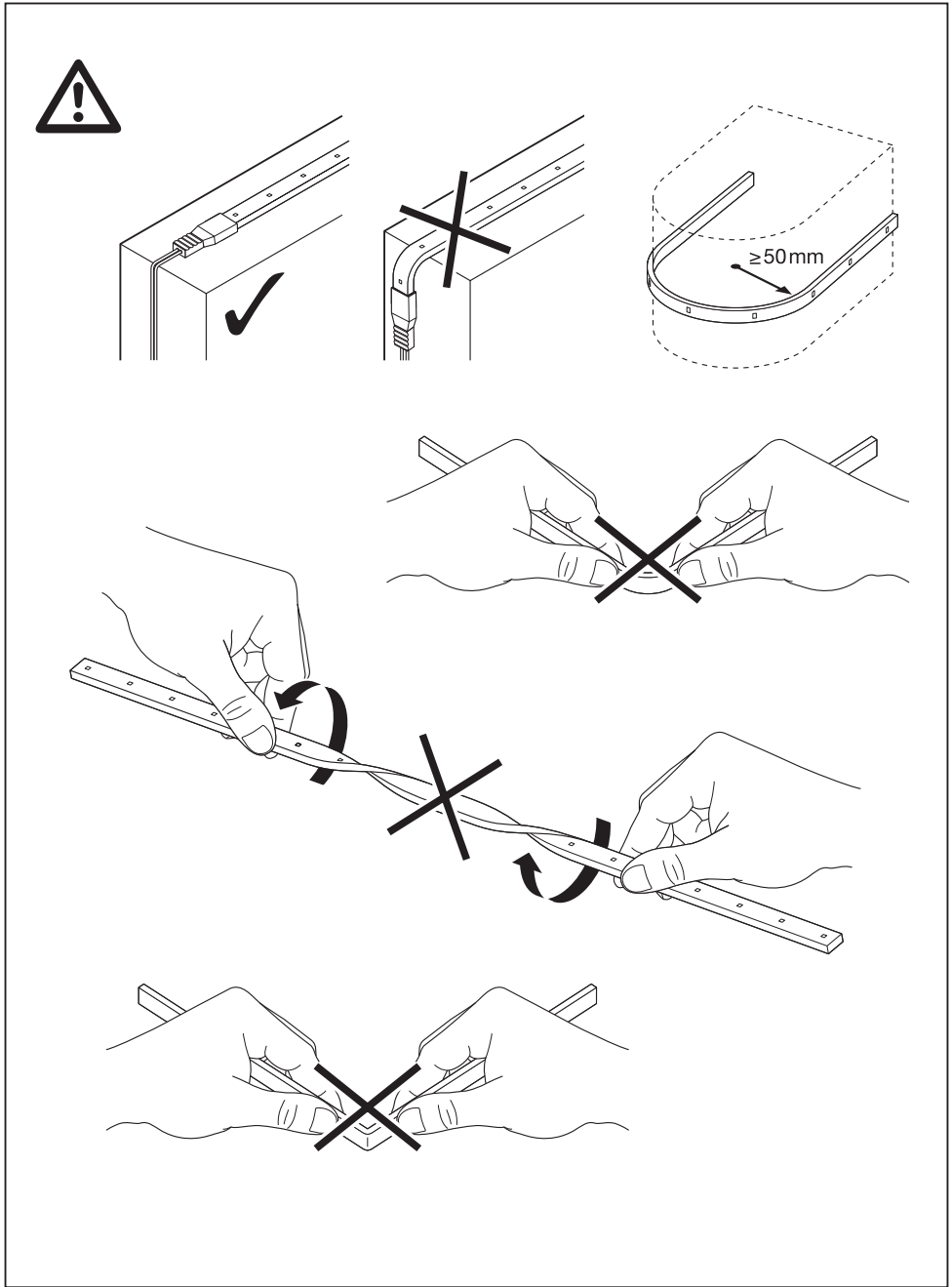

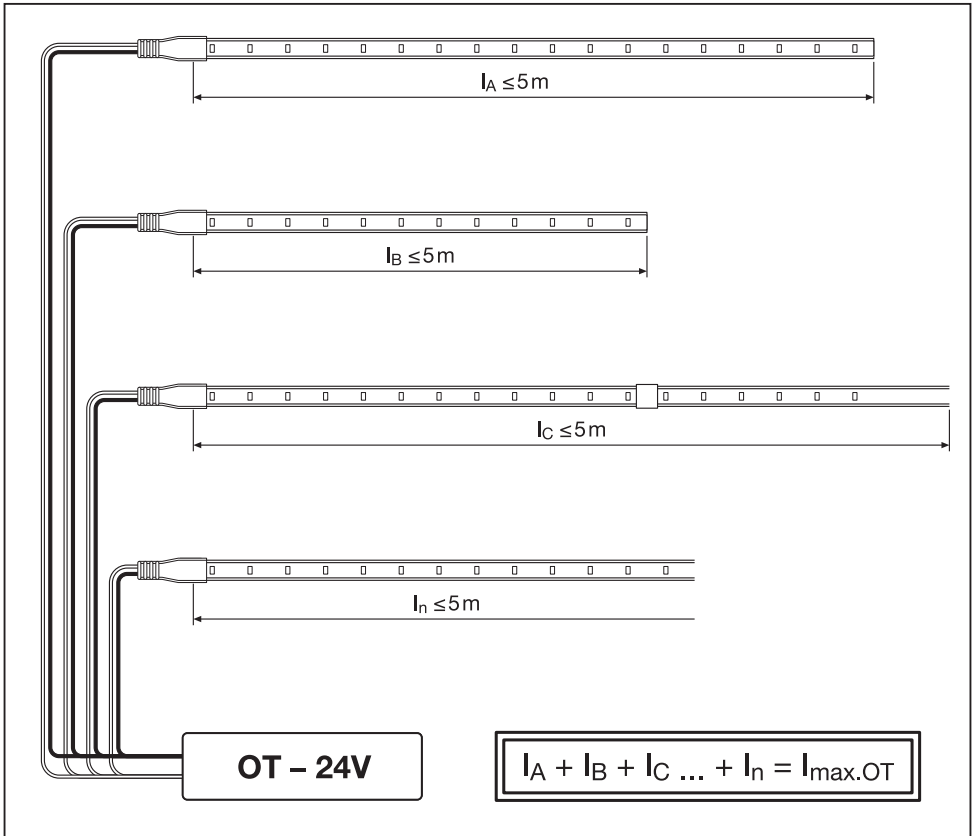
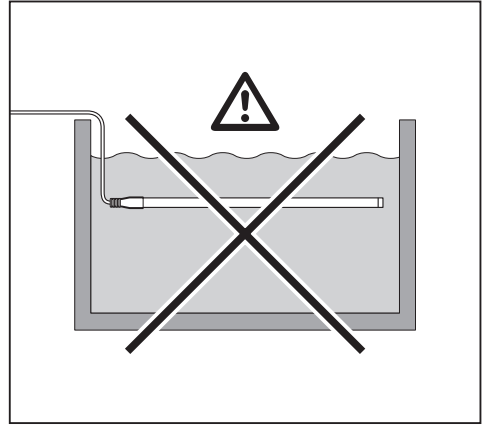
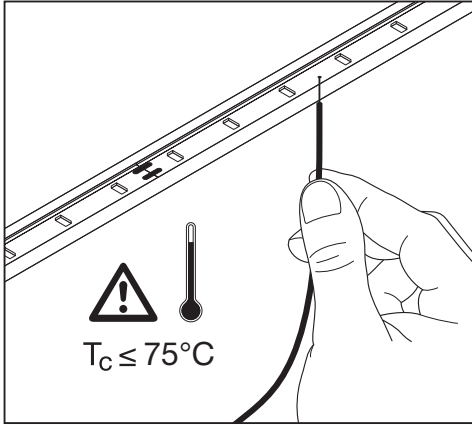

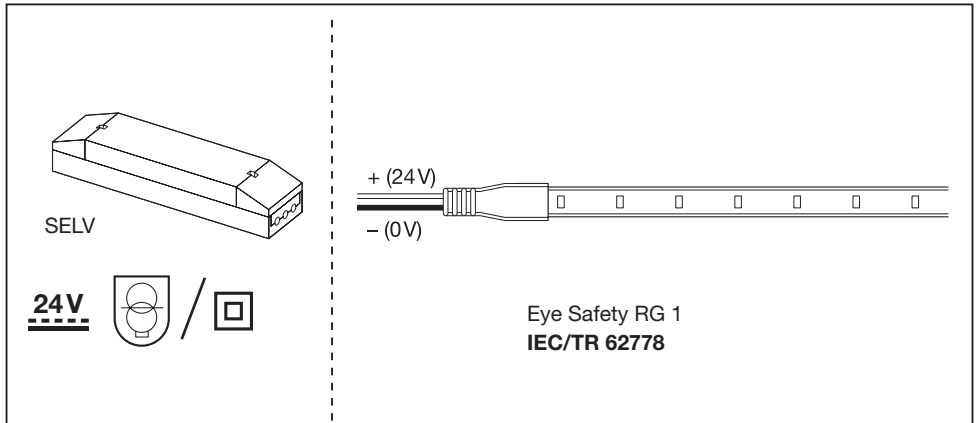

Safety Information

- Pay attention to ESD steps when mounting the module.
- The LED module itself and all its components must not be mechanically stressed.
- Assembly must not damage or destroy conducting paths on the circuit board.
- To avoid mechanical damage, the LED modules should be attached securely to the intended substrate. Heavy vibration should be avoided.
- Installation of LED modules (with power supplies) needs to be made with regard to all applicable electrical and safety standards.
- Observe correct polarity! Incorrect polarity will lead to no light emission and may cause damage of the LED module.
- Parallel connection is highly recommended as safe electrical operation mode. Serial connection is not recommended. Unbalanced voltage drop can cause hazardous overload and damage the LED module.
- The maximum length of BF shortpitch is 5M with power feed at one end.
- When mounting on metallic or otherwise conductive surfaces, there needs to be an electrical isolation at soldering points between module and the mounting surface.
- Please ensure that the power supply is of adequate power to operate the total load.
- LED modules are dimmable by means of PWM (pulse width modulation). It is recommended using the following OSRAM control gears: OPTOTRONIC® OT DIM.
- The LED module must not be operated in places which are directly exposed to water or moisture, as it is for indoor applications.
- Modules may get damaged by corrosion. It is the user's responsibility to provide suitable protection against corrosive agents such as moisture and condensation and other harmful elements.
- For applications involving exposure to humidity and dust the module must be protected by a fixture or housing with a suitable protection class.

Assembly Information

-  **Built-in LED module**, designed to be installed within a luminaire, a box or in an enclosure that provides protection according to the requirements of luminaires safety standards (e.g. IEC 60598 series). No liabilities of manufacturer or importer can be accepted if the product is used otherwise.
- Please use 24V constant Voltage, SELV LED driver only.
- The smallest electrical unit (SEU) (50mm - 6 LEDs) can be removed by cutting at the printed marks at the side.
- After cutting connect the module via Osram recommended IP54 CONNECTOR. Insert module into connector and apply pressure on a hard surface until locked.
- The mounting of the single LED Strip is facilitated by means of the double-sided adhesive on the back surface of the module. Care must be taken to provide a clean and dry mounting surface, free of oils or silicone coatings as well as dirt particle. The mounting substrate must have sufficient structural integrity. Take care to completely remove the adhesive backing. Once the module is appropriately positioned, press on the module with about 20N/cm² (refer to application techniques of Tesla adhesive transfer tapes). To support adhesion at higher temperatures, use additional mounting brackets if temperature exceeds T_c = 75°C.
- In case of moving already installed module roll from one place to another, use suitable fresh double sided tape for reinstallation.
- The minimum bending radius is 5 cm.
- If temperature exceeds T_c = 75°C, additional mounting brackets are needed.
- Pay attention to avoid highly corrosive atmospheres, e.g. permanent high humidity or Hydrogen Sulfide (H₂S). With current LED technology, H₂S is causing accelerated corrosion which will lead to shortened time life or premature failure. Sources for H₂S may be rubber, foamed rubber, soft-foam-tapes, sealing on rubber basis, natural sources (e.g. sulfur springs), etc. To avoid H₂S from sulfur-vulcanized rubber it is necessary to switch to silicon based materials or rubber that is Peroxide-cross linked.
- Indication may be found in the material datasheet of the rubber supplier.

OSRAM GmbH
 Berliner Allee 65
 86153 Augsburg
 Germany
www.osram.com

CT0449059
 G15099291
 2021-06-03

