

Partial flux — Measurement reliability of lensed LEDs

Application Note

Published by **ams-OSRAM AG**

Tobelbader Strasse 30,
8141 Premstaetten Austria
Phone +43 3136 500-0
ams-osram.com
© All rights reserved



Partial flux — Measurement reliability of lensed LEDs

Application Note No. AN014



Valid for:
lensed LEDs

Abstract

Most LED manufacturers use units of luminous intensity (cd) for the measurement and classification of LED brightness. For numerous LED types, this procedure is reliable and reproducible. However, for LEDs with narrow emission angle characteristics, this method is inadequate. This application note describes the procedures for measuring luminous intensity, partial flux and luminous flux, along with the advantages and disadvantages relating to LED design.

Table of contents

| | |
|--|---|
| 1 Luminous intensity measurement | 3 |
| 2 Luminous flux measurement..... | 4 |
| 3 Partial flux measurement | 5 |
| 4 Tolerance considerations | 7 |
| 5 Summary | 9 |

1 Luminous intensity measurement

Luminous intensity is measured in the units of cd. The luminous intensity I_v is calculated from the luminous flux $d\Phi_v$, which passes through a solid angle $d\Omega$:

$$I_v = \frac{d\Phi_v}{(d\Omega)} \quad \left(cd = \frac{lm}{sr} \right)$$

ams-OSRAM follows the recommendations of the International Commission on Illumination (CIE) for luminous intensity measurements of LEDs as described in Publication 127-1997, in which the detector is positioned at a distance of 100 mm from the tip of the LED to be measured (see Figure 1). The light-sensitive surface must be round and have an area of 1 cm². This geometry results in a solid angle of 0.01 sr (Steradian) through which the luminous intensity is measured.

Figure 1: Luminous intensity measurement

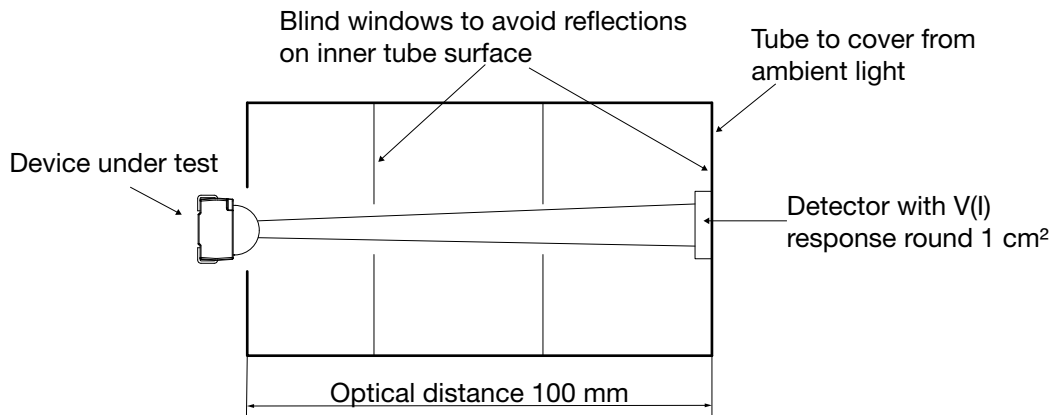

In the 2D projection, the solid angle of 0.01 sr corresponds to an aperture angle of $\pm 3.2^\circ$ (see Figure 2). In order for luminous intensity to be measured in a reproducible manner, the distribution of luminous intensity within the solid angle must remain constant. Factors which can negatively influence a luminous intensity measurement include:

- Component tolerances (e.g. variations in the emission angle, squint angle)
- Positioning tolerance during measurement (e.g. tipping the component during contact)

The tolerances described above can be neglected for components with a large emission angle (e.g. 120°) and without primary optics, for example, TOPLED[®], Power TOPLED[®], SIDELED[®] and Mini TOPLED[®].

For components with a narrow emission angle ($< \pm 20^\circ$), the measurement difficulties described can arise. The tolerances can prevent reproducible measurements from being carried out for these LEDs. The nature of this problem is not dependent on the construction or manufacturer of the LED.

2 Luminous flux measurement

In contrast to the luminous intensity measurement which is used to measure the intensity of light passing through a narrow angle, the luminous flux measurement is used to measure the total power of light emitted in all directions. The unit of measurement for luminous flux is the Lumen (lm). From a technical standpoint, this measurement can be carried out in two different ways: either by means of a goniometer or by utilizing a so-called integrating sphere.

With a goniometer, the light intensity is recorded as a function of the emission angle. By using the inverse of the luminous intensity formula, the luminous flux can be ascertained:

$$\Phi_V = \int_{4\pi} I_V d\Omega \quad (\text{lm})$$

Although this method provides the most precise measurement of the luminous flux emitted from an LED, it is extremely time-consuming, and is therefore not well suited for production environments.

When measuring luminous flux by means of an integrating sphere, the device under test is placed inside a hollow sphere whose inner surface is coated with a high-grade diffuse material. The multiple reflections of light created by the inner surface of the sphere serve to create a distribution of illumination which is proportional to the luminous flux emitted from the LED. By recording the illumination intensity present at an opening in the sphere, the entire luminous flux can be measured. The difficulty in measuring luminous flux with this procedure arises from the type-specific calibration which is necessary, along with the requirement that the device under test must be completely enclosed within the sphere. Type-specific calibration of the integrating sphere implies that in order to carry out accurate measurements, a reference light source must be used which corresponds to the form and emission characteristics of the device under test.

If this requirement were to be extended to the production environment, a large number of calibrations would be necessary for the various types of LEDs. The logistical problems which arise are not in keeping with the cost effectiveness gained through the mass production of LEDs. The positional requirements for such a measurement also impact the highly-automated, cost-effective production of LEDs. Together, these two difficulties lead to enormous expenditures which is required to carry out a “true” flux measurement under production conditions.

Due to their robust characteristics and ever increasing brightness, LEDs are continually found in new applications. Along with the capture of new applications, new demands are placed on the LEDs. In order to be able to better address these demands, ams-OSRAM has developed a new measurement technique for LEDs with narrow emission angles. The partial flux measurement technique takes into consideration the numerous applications for narrow-angle LEDs while smoothing out the tolerances created by errors during measurement.

3 Partial flux measurement

In comparison to luminous intensity measurements, the partial flux measurement extends the solid angle used for the measurement from 0.01 sr to approximately 0.38 sr; the aperture angle is thus increased from $\pm 3.2^\circ$ to $\pm 20^\circ$ (see Figure 2).

Figure 2: Comparison of luminous intensity and partial flux measurement

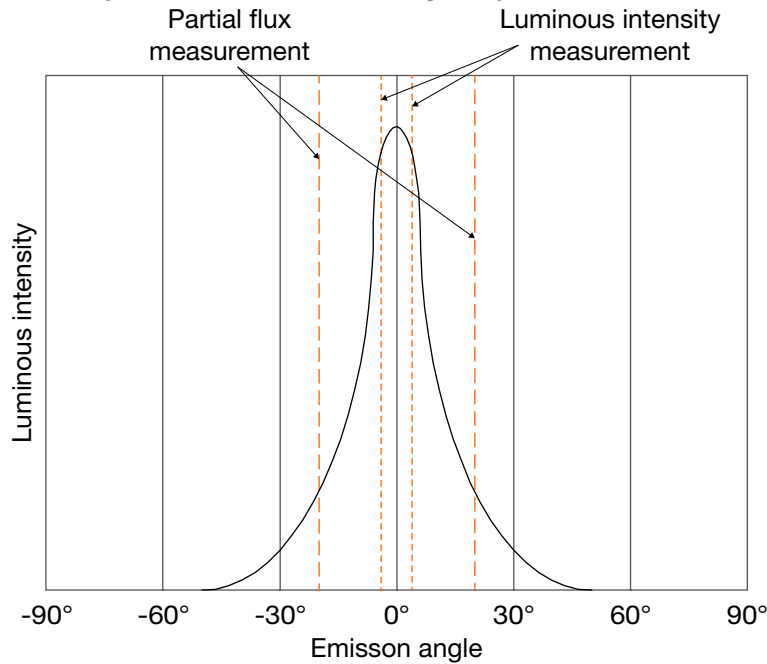

In order to achieve the partial flux measurement geometry described above, the tip of the LED to be measured is positioned at a distance of 19.2 mm from the measurement opening of an integrating sphere. The measurement opening has a diameter of 14 mm, which results in the desired measurement angle of $\pm 20^\circ$. This allows only the luminous flux from the LED which lies within the acceptance angle created by the integrating sphere to be applied to the detector.

This angular range significantly increases the measurement reproducibility for LEDs with narrow emission angles. In addition, the new measurement geometry is better suited to current applications employing narrow-angled LEDs than that used for classical LED luminous intensity measurements. For these new applications, a secondary optic with a limited aperture angle is often used, but it is always greater than the $\pm 3.2^\circ$ angle used for luminous intensity measurements.

In order to emphasize the new nature of the partial flux measurements and to avoid possible confusion between the units of measurement for luminous flux, luminous intensity and partial flux measurements, partial flux measurements are expressed in terms of illumination. The unit of measurement, as a result, is the Lux (lx):

$$E_v = \frac{d\Phi_v}{m^2} \quad \left(lx = \frac{lm}{m^2} \right)$$

4 Tolerance considerations

The following section addresses errors in measurement for narrow-angled LEDs. Figures 3 and 4 show the influence of measurement techniques on mechanical tolerances. This can arise, for example, from squinting of the device, or from the positional accuracy of the device.

Figure 3: Positional accuracy (e.g. squinting, alignment failures)

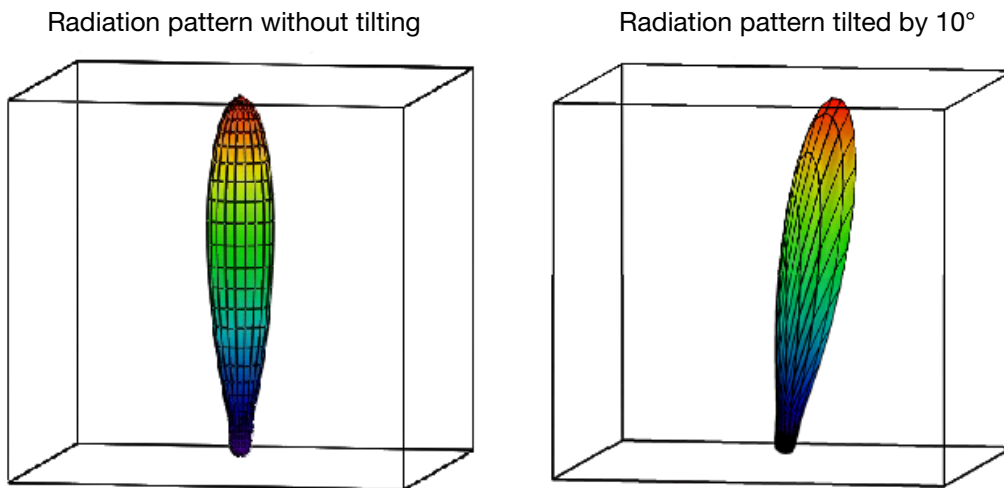
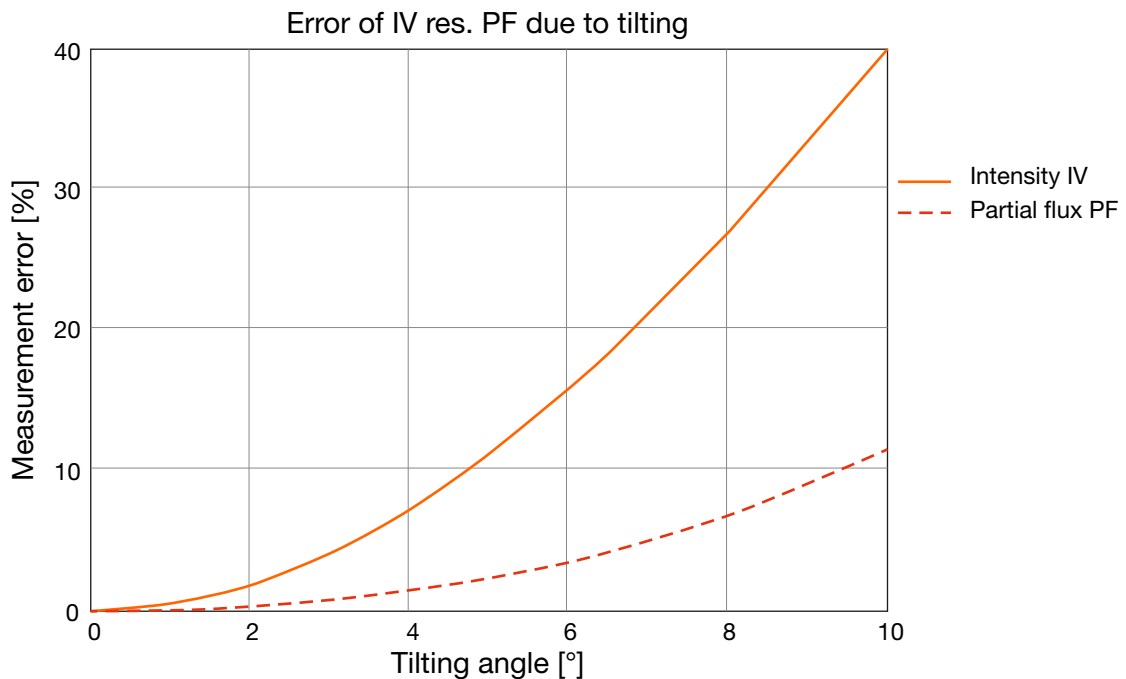

Figure 4: Error analysis – positional accuracy



For intensity measurements, a deviation of 4° leads to an error of 7.2 %. In comparison, the error introduced with the partial flux measurement is only 1.4 %. The reproducibility of the measurement is therefore significantly improved.

Figure 5 shows three emission patterns which each result in a flux of 1 lm. Despite the identical luminous flux, the luminous intensity at 0° varies from 1.9 cd to 2.6 cd; this corresponds to a variance of 31 %. Here, the partial flux measurement proves much more stable, exhibiting only a variance of 14.2 %. Since most applications for narrow-angle LEDs utilize almost the entire width of the angular emission characteristic, the advantages of the partial flux measurement are clearly visible in comparison to I_V measurements for narrow-angle LEDs. The observation of measurement accuracy is shown in Table 1.

Figure 5: Emission characteristics

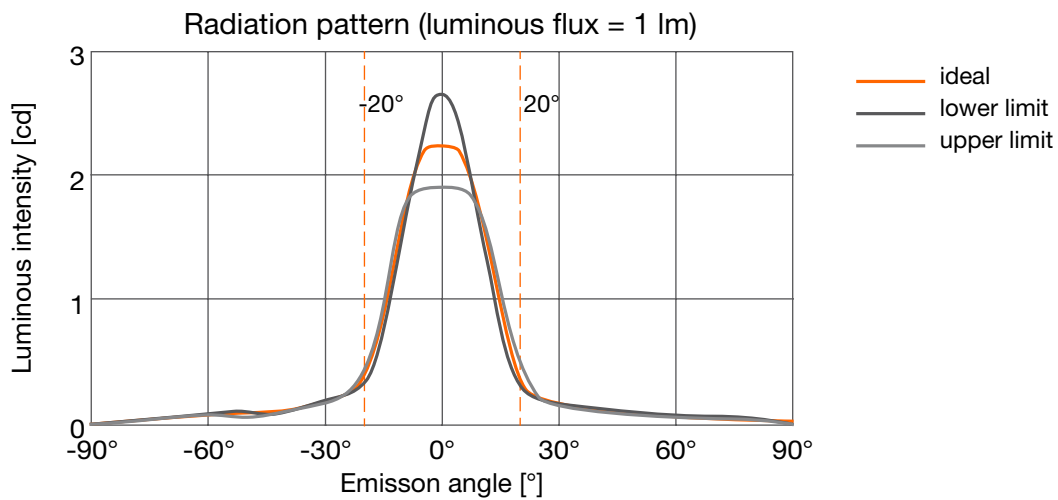

Table 1: Measurement accuracy of emission characteristics

| | Narrow | Ideal | Broad | Deviation |
|------------------------------|-------------------------------|-------------------------------|-------------------------------|--------------------------|
| Luminous flux (2π): | $\Phi_{lo} = 1.00 \text{ lm}$ | $\Phi_{id} = 1.00 \text{ lm}$ | $\Phi_{hi} = 1.00 \text{ lm}$ | (normalized) |
| Luminous intensity I_V : | $I_{V,lo} = 2.60 \text{ cd}$ | $I_{V,id} = 2.25 \text{ cd}$ | $I_{V,hi} = 1.91 \text{ cd}$ | $\Delta_{I_V} = 31.0 \%$ |
| Partial flux | $PF_{lo} = 2.7 \text{ klx}$ | $PF_{id} = 3.0 \text{ klx}$ | $PF_{hi} = 3.1 \text{ klx}$ | $\Delta_{PF} = 14.2 \%$ |

Why isn't a flux measurement simply performed? A flux measurement requires the component to be completely enclosed in an integrating sphere. For most LED housings, this is very difficult to implement in mass production, due to their construction. If the LED is not completely enclosed, compromises will be introduced, and the flux will not be measured in its entirety. In the strictest sense, this should not even be declared as a flux measurement. Furthermore, the entire diffused light from a component is measured. For narrow-angled LEDs, the diffused light is normally not significant.

5 Summary

The three measurement techniques described — luminous intensity, partial flux measurement and flux measurement — each have their own legitimacy. Due to the design and emission characteristics of narrow-angle LEDs, the partial flux measurement technique provides considerable advantages. By means of this development process, ams-OSRAM employs a measurement technique which is well suited for mass production and whose reproducibility is considerably greater than that provided by luminous intensity measurements.

ABOUT ams OSRAM Group (SIX: AMS)

The ams OSRAM Group (SIX: AMS) is a global leader in optical solutions. By adding intelligence to light and passion to innovation, we enrich people's lives. This is what we mean by Sensing is Life. With over 110 years of combined history, our core is defined by imagination, deep engineering expertise and the ability to provide global industrial capacity in sensor and light technologies. Our around 24,000 employees worldwide focus on innovation across sensing, illumination and visualization to make journeys safer, medical diagnosis more accurate and daily moments in communication a richer experience. Headquartered in Premstaetten/Graz (Austria) with a co-headquarters in Munich (Germany), the group achieved over EUR 5 billion revenues in 2021. Find out more about us on <https://ams-osram.com>

DISCLAIMER

PLEASE CAREFULLY READ THE BELOW TERMS AND CONDITIONS BEFORE USING THE INFORMATION SHOWN HEREIN. IF YOU DO NOT AGREE WITH ANY OF THESE TERMS AND CONDITIONS, DO NOT USE THE INFORMATION.

The information provided in this general information document was formulated using the utmost care; however, it is provided by ams-OSRAM AG or its Affiliates* on an "as is" basis. Thus, ams-OSRAM AG or its Affiliates* does not expressly or implicitly assume any warranty or liability whatsoever in relation to this information, including – but not limited to – warranties for correctness, completeness, marketability, fitness for any specific purpose, title, or non-infringement of rights. In no event shall ams-OSRAM AG or its Affiliates* be liable – regardless of the legal theory – for any direct, indirect, special, incidental, exemplary, consequential, or punitive damages arising from the use of this information. This limitation shall apply even if ams-OSRAM AG or its Affiliates* has been advised of possible damages. As some jurisdictions do not allow the exclusion of certain warranties or limitations of liabilities, the above limitations and exclusions might not apply. In such cases, the liability of ams-OSRAM AG or its Affiliates* is limited to the greatest extent permitted in law.

ams-OSRAM AG or its Affiliates* may change the provided information at any time without giving notice to users and is not obliged to provide any maintenance or support related to the provided information. The provided information is based on special conditions, which means that the possibility of changes cannot be precluded.

Any rights not expressly granted herein are reserved. Other than the right to use the information provided in this document, no other rights are granted nor shall any obligations requiring the granting of further rights be inferred. Any and all rights and licenses regarding patents and patent applications are expressly excluded.

It is prohibited to reproduce, transfer, distribute, or store all or part of the content of this document in any form without the prior written permission of ams-OSRAM AG or its Affiliates* unless required to do so in accordance with applicable law..

* ("Affiliate" means any existing or future entity: (i) directly or indirectly controlling a Party; (ii) under the same direct, indirect or joint ownership or control as a Party; or (iii) directly, indirectly or jointly owned or controlled by a Party. As used herein, the term "control" (including any variations thereof) means the power or authority, directly or indirectly, to direct or cause the direction of the management and policies of such Party or entity, whether through ownership of voting securities or other interests, by contract or otherwise.)



For further information on our products please see the Product Selector and scan this QR Code.

Published by ams-OSRAM AG
Tobelbader Strasse 30, 8141 Premstaetten, Austria
ams-osram.com © All Rights Reserved.

Published by ams-OSRAM AG

Tobelbader Strasse 30,
8141 Premstaetten Austria

Phone +43 3136 500-0

ams-osram.com

© All rights reserved

