

Product Document



Application Note

AN001020

Proximity Calibration Using POFFSET

v1-00 • 2021-Apr-28

Content Guide

1	Introduction	3	6	Reference Documents	10
2	Proximity Response	5	7	Revision Information	11
2.1	Reflective Light	5	8	Legal Information.....	12
3	Proximity Calibration	7			
3.1	Offset Calibration.....	7			
4	Summary	8			
5	Glossary.....	9			

1 Introduction

A device with the proximity function measures the amount of reflected IR light at the IR photodiode detector.

This IR light is a combination of ambient IR energy and reflected IR energy from a pulsed emitter. The reflected IR energy is made up of IR energy reflected from a target plus unintended IR reflections from the optical stack and from within the device itself. These unintentional IR reflections are referred to as crosstalk. The amount of optical crosstalk is determined by measuring the reflected IR pulse energy without a target being present (i.e. open-air crosstalk).

The crosstalk can be subtracted from the pulsed IR energy to leave behind the signal reflected from the target. A simple illustration of this is shown in Figure 1.

Figure 1:
Crosstalk Subtraction Block Diagram

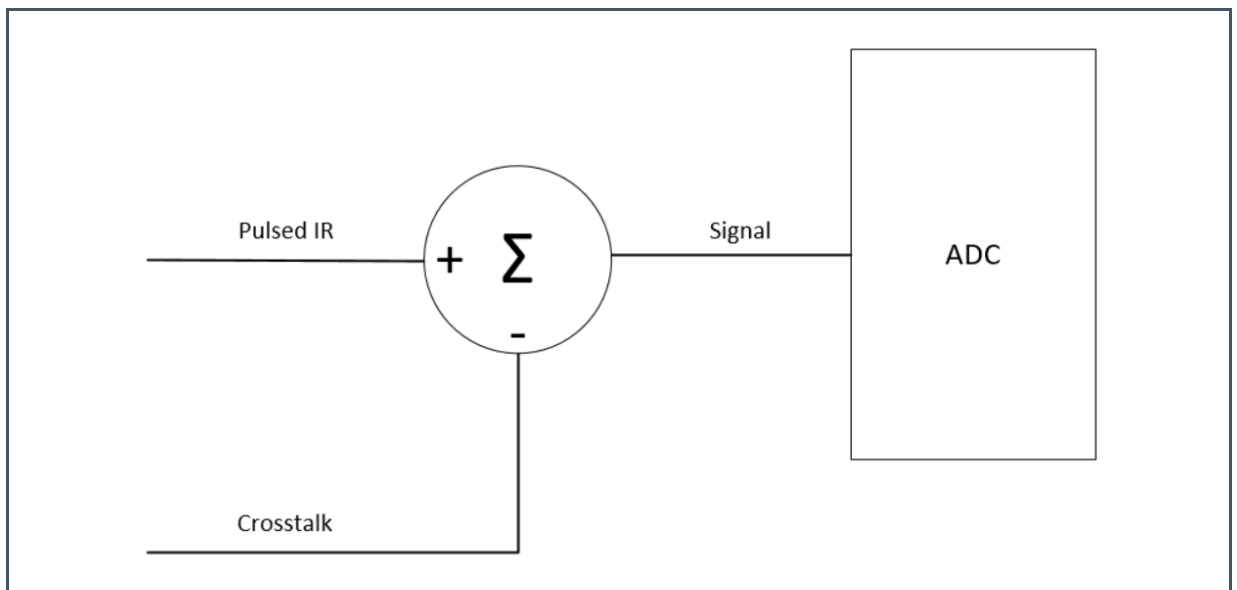

The process of subtracting the estimated crosstalk offset voltage at the ADC input is called proximity offset calibration.

Figure 2:
Proximity Sensor Architecture

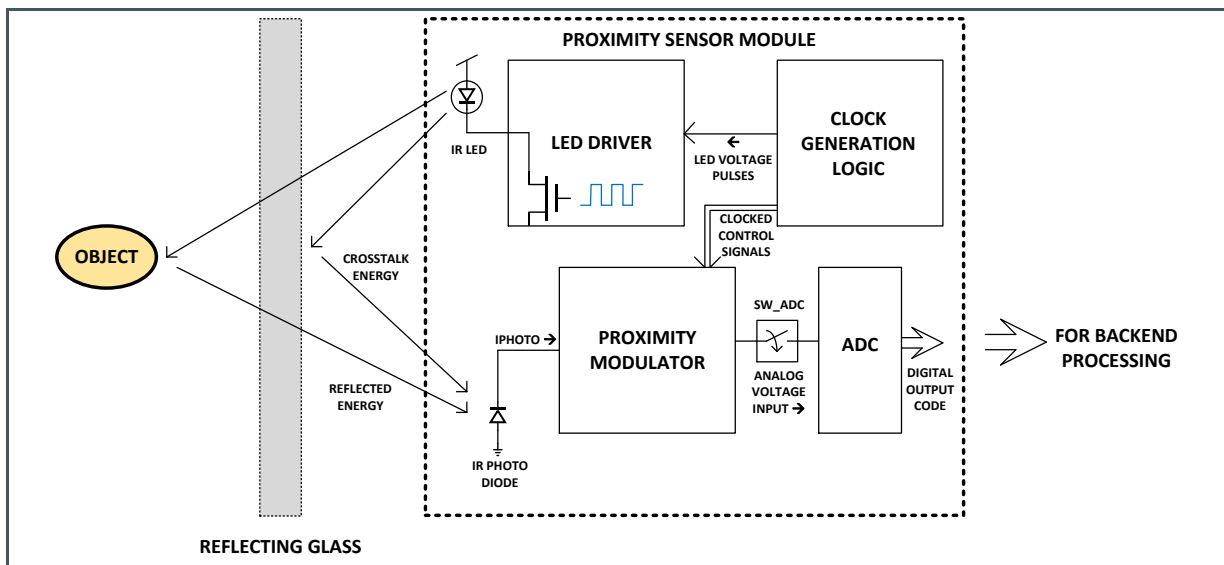

The purpose of this application note is to explain the process of proximity offset calibration within the system.

2 Proximity Response

2.1 Reflective Light

In an ideal world 100% of the pulsed IR energy would pass through the glass, 100% would reflect off the target (with no absorption) and 100% would return to the sensor no amount of propagation loss. There would be zero offset in the device and no optical crosstalk. However, it is a non-ideal world.

Figure 3:
Ideal System

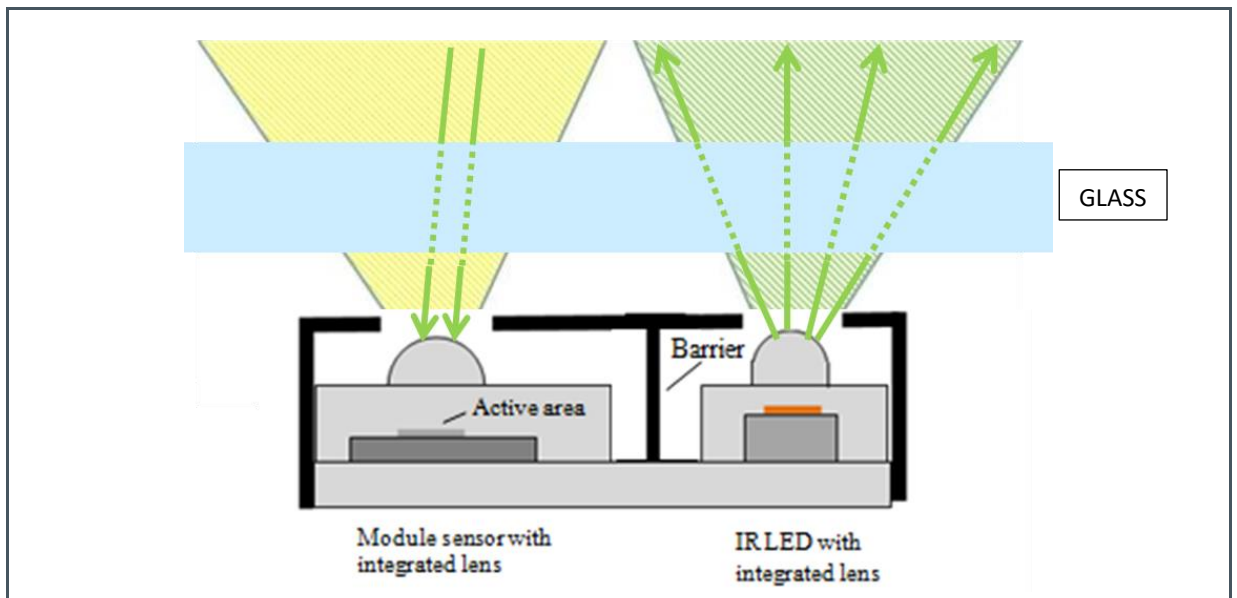

Due to mechanical alignment, air gap, glass thickness, glass physical characteristics (reflection, scattering, absorption, etc.) and other phenomena, the pulsed IR energy does not behave in an ideal manner.

Figure 4:
Simplified Optical Reflected Light

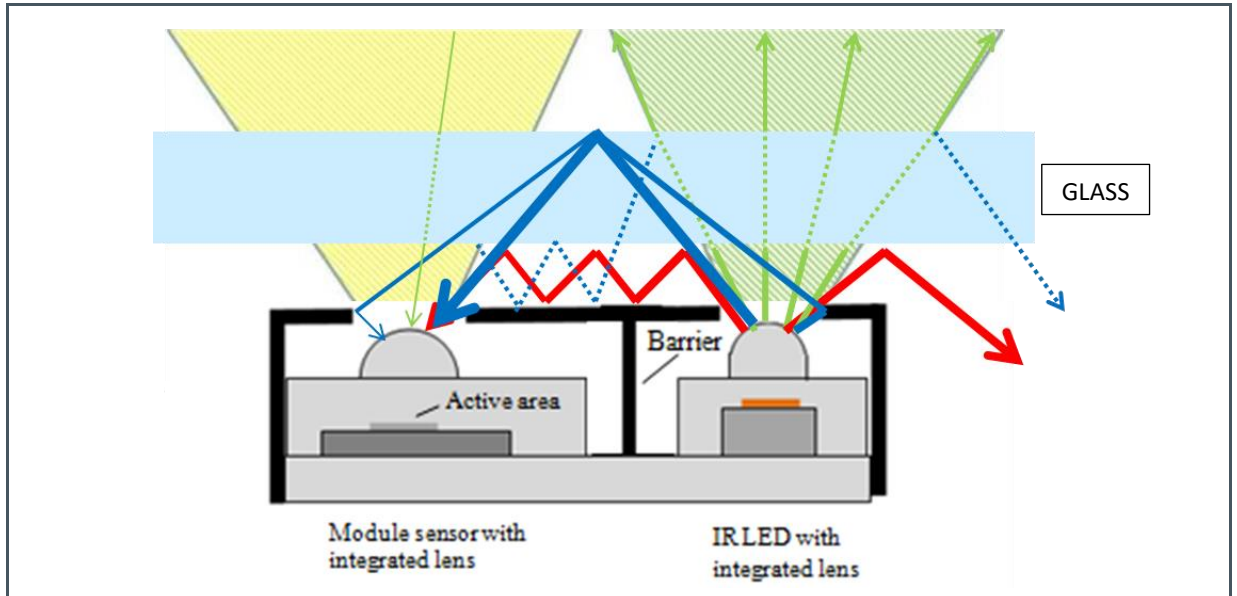

Figure 4 is a highly simplified diagram of reflective light in a real-world system. Fresnel reflection and refraction occurs whenever light enters or exits the glass, but is not shown in this picture. Attenuation happens with every reflection. Due to the small distance between the sensor and IR LED/VCSEL this induces crosstalk.

3 Proximity Calibration

3.1 Offset Calibration

A calibration starts with user settings for gain, pulse length, number of pulses, drive current. Then the resulting no-target ADC value is used to determine the amount of crosstalk. Upon completion of the offset calibration process, the resulting offset value is stored in the **POFFSETx** registers.

Before starting, the flags in **CALIBSTAT** get cleared automatically by clearing the cien interrupt by writing '1' to **STATUS.cint**.

1. Remove the target from above the device.
2. User sets the **CALIBCFG2.binsrch_target**.

The target value is configurable in **CALIBCFG2.binsrch_target** – on one hand one would like a value that is close to zero, on the other hand one would like to prevent measuring too many zeroes (PDATA=0) during regular run time (as PDATA=0 cannot distinguish whether it's 'just' zero, or whether it's actually quite negative).

NOTE: The **CALIBCFG2.binsrch_target** value sets the PDATA value that the calibration attempts to achieve.

3. User sets the **CALIB.start_offset_calib** bit to start calibration.
4. When cien is asserted, **CALIBSTAT** will show the result details.

The **calib_finished** bit must be asserted, otherwise there was an error.

4 Summary

The calibration process includes optimizing the proximity configuration parameters, determining acceptable detect and release thresholds while balancing the tradeoffs between power consumption, noise, and performance. This is an iterative process.

5 Glossary

IR – Infrared

CIEN – Calibration Interrupt Enable

LED – Light Emitting Diode

VCSEL - Vertical-cavity surface-emitting laser

6 Reference Documents



For further information, please refer to the following documents:

- AN000556: Proximity Detection: Optimizing Proximity Parameters
-

7 Revision Information

Changes from previous version to current revision v1-00	Page
Initial production version	

- Page and figure numbers for the previous version may differ from page and figure numbers in the current revision.
- Correction of typographical errors is not explicitly mentioned.

8 Legal Information

Copyrights & Disclaimer

Copyright ams AG, Tobelbader Strasse 30, 8141 Premstaetten, Austria-Europe. Trademarks Registered. All rights reserved. The material herein may not be reproduced, adapted, merged, translated, stored, or used without the prior written consent of the copyright owner.

Information in this document is believed to be accurate and reliable. However, ams AG does not give any representations or warranties, expressed or implied, as to the accuracy or completeness of such information and shall have no liability for the consequences of use of such information.

Applications that are described herein are for illustrative purposes only. ams AG makes no representation or warranty that such applications will be appropriate for the specified use without further testing or modification. ams AG takes no responsibility for the design, operation and testing of the applications and end-products as well as assistance with the applications or end-product designs when using ams AG products. ams AG is not liable for the suitability and fit of ams AG products in applications and end-products planned.

ams AG shall not be liable to recipient or any third party for any damages, including but not limited to personal injury, property damage, loss of profits, loss of use, interruption of business or indirect, special, incidental or consequential damages, of any kind, in connection with or arising out of the furnishing, performance or use of the technical data or applications described herein. No obligation or liability to recipient or any third party shall arise or flow out of ams AG rendering of technical or other services.

ams AG reserves the right to change information in this document at any time and without notice.

RoHS Compliant & ams Green Statement

RoHS Compliant: The term RoHS compliant means that ams AG products fully comply with current RoHS directives. Our semiconductor products do not contain any chemicals for all 6 substance categories plus additional 4 substance categories (per amendment EU 2015/863), including the requirement that lead not exceed 0.1% by weight in homogeneous materials. Where designed to be soldered at high temperatures, RoHS compliant products are suitable for use in specified lead-free processes.

ams Green (RoHS compliant and no Sb/Br/Cl): ams Green defines that in addition to RoHS compliance, our products are free of Bromine (Br) and Antimony (Sb) based flame retardants (Br or Sb do not exceed 0.1% by weight in homogeneous material) and do not contain Chlorine (Cl not exceed 0.1% by weight in homogeneous material).

Important Information: The information provided in this statement represents ams AG knowledge and belief as of the date that it is provided. ams AG bases its knowledge and belief on information provided by third parties, and makes no representation or warranty as to the accuracy of such information. Efforts are underway to better integrate information from third parties. ams AG has taken and continues to take reasonable steps to provide representative and accurate information but may not have conducted destructive testing or chemical analysis on incoming materials and chemicals. ams AG and ams AG suppliers consider certain information to be proprietary, and thus CAS numbers and other limited information may not be available for release.

Headquarters

ams AG
Tobelbader Strasse 30
8141 Premstaetten
Austria, Europe
Tel: +43 (0) 3136 500 0

Please visit our website at www.ams.com

Buy our products or get free samples online at www.ams.com/Products

Technical Support is available at www.ams.com/Technical-Support

Provide feedback about this document at www.ams.com/Document-Feedback

For sales offices, distributors and representatives go to www.ams.com/Contact

For further information and requests, e-mail us at ams_sales@ams.com