

# SFH 4850 E7800

## Metal Can® TO18

Infrared Emitter (850 nm)

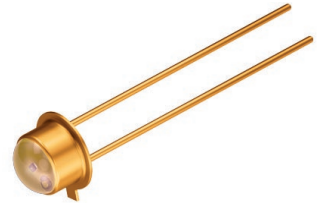

## Applications

- Industrial Automation (Machine Controls, Light Barriers, Vision Controls)

## Features:

- Package: clear epoxy
- ESD: 2 kV acc. to ANSI/ESDA/JEDEC JS-001 (HBM, Class 2)
- Wavelength 850nm
- Anode is electrically connected to the case
- Short switching times
- Spectral match with silicon photodetectors
- Measured with a 1.1mm aperture.
- DIN humidity category in acc. with DIN 40 040 GQG

## Ordering Information

Type	Radiant intensity <sup>1)</sup> $I_F = 100 \text{ mA}; t_p = 20 \text{ ms}$ $I_e$	Radiant intensity <sup>1)</sup> typ. $I_F = 100 \text{ mA}; t_p = 20 \text{ ms}$ $I_e$	Ordering Code
SFH 4850 E7800	4.0 ... 20.0 mW/sr	10 mW/sr	Q65110A2093

## Maximum Ratings

$T_A = 25\text{ °C}$

Parameter	Symbol	Values
Operating temperature	$T_{op}$	min. -40 °C max. 80 °C
Storage temperature	$T_{stg}$	min. -40 °C max. 80 °C
Forward current	$I_F$	max. 200 mA
Surge current $t_p \leq 1000\ \mu\text{s}; D = 0$	$I_{FSM}$	max. 1 A
Reverse voltage <sup>2)</sup>	$V_R$	max. 12 V
Power consumption	$P_{tot}$	max. 470 mW
ESD withstand voltage acc. to ANSI/ESDA/JEDEC JS-001 (HBM, Class 2)	$V_{ESD}$	max. 2 kV

## Characteristics

$I_F = 100 \text{ mA}$ ;  $t_p = 20 \text{ ms}$ ;  $T_A = 25 \text{ °C}$

Parameter	Symbol		Values
Peak wavelength	$\lambda_{\text{peak}}$	typ.	860 nm
Centroid wavelength	$\lambda_{\text{centroid}}$	typ.	850 nm
Spectral bandwidth at 50% $I_{\text{rel,max}}$ (FWHM)	$\Delta\lambda$	typ.	30 nm
Half angle	$\varphi$	typ.	23 °
Dimensions of active chip area	L x W	typ.	0.3 x 0.3 mm x mm
Rise time (10% / 90%) $I_F = 100 \text{ mA}$ ; $R_L = 50 \text{ }\Omega$	$t_r$	typ.	12 ns
Fall time (10% / 90%) $I_F = 100 \text{ mA}$ ; $R_L = 50 \text{ }\Omega$	$t_f$	typ.	12 ns
Forward voltage	$V_F$	typ. max.	1.5 V 1.8 V
Forward voltage $I_F = 1 \text{ A}$ ; $t_p = 100 \text{ }\mu\text{s}$	$V_F$	typ. max.	2.4 V 3 V
Reverse current <sup>2)</sup> $V_R = 5 \text{ V}$	$I_R$	max.	10 $\mu\text{A}$
Radiant intensity <sup>1)</sup> $I_F = 1 \text{ A}$ ; $t_p = 100 \text{ }\mu\text{s}$	$I_e$	typ.	75 mW/sr
Total radiant flux <sup>3)</sup>	$\Phi_e$	typ.	50 mW
Temperature coefficient of voltage	$TC_V$	typ.	-0.7 mV / K
Temperature coefficient of brightness	$TC_I$	typ.	-0.5 % / K
Temperature coefficient of wavelength	$TC_\lambda$	typ.	0.3 nm / K
Thermal resistance junction case real	$R_{\text{thJC}}$	max.	160 K / W
Thermal resistance junction ambient real	$R_{\text{thJA}}$	max.	450 K / W

## Brightness Groups

$T_A = 25\text{ °C}$

Group	Radiant intensity $I_F = 100\text{ mA}; t_p = 20\text{ ms}$ min. $I_e$	Radiant intensity $I_F = 100\text{ mA}; t_p = 20\text{ ms}$ max. $I_e$
	P	4.0 mW/sr
Q	6.3 mW/sr	12.5 mW/sr
R	10.0 mW/sr	20.0 mW/sr

Only one group in one packing unit (variation lower 2:1).

E7800: An aperture is used in front of the component for measurement of the radiant intensity and the half angle (diameter of the aperture: 1.1 mm; distance of aperture to case back side: 4.0 mm). This ensures that solely the radiation in axial direction emitting directly from the chip surface will be evaluated during measurement of the radiant intensity. Radiation reflected by the bottom plate (stray radiation) will not be evaluated. These reflections impair the projection of the chip surface by additional optics (e.g. long-range light reflection switches). In respect of the application of the component, these reflections are generally suppressed by apertures as well. This measuring procedure corresponding with the application provides more useful values. This aperture measurement is denoted by "E 7800" added to the type designation.

## Relative Spectral Emission 4), 5)

$$I_{e,rel} = f(\lambda); I_F = 100\text{ mA}; t_p = 20\text{ ms}$$

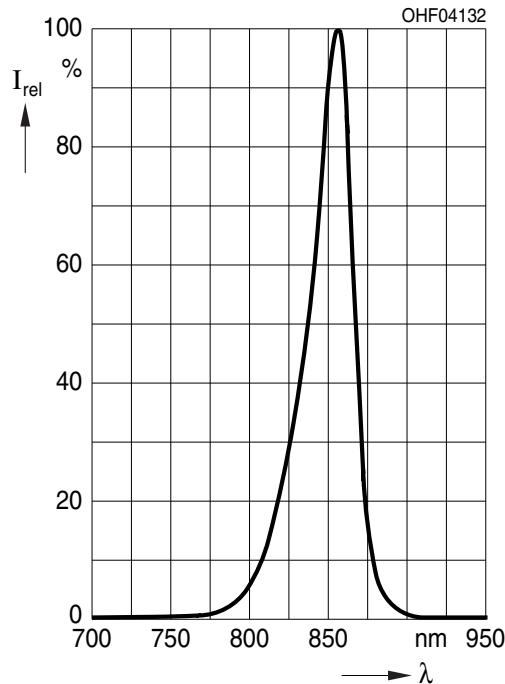

Discontinued

**Radiation Characteristics** 4), 5)

$I_{e,rel} = f(\varphi)$

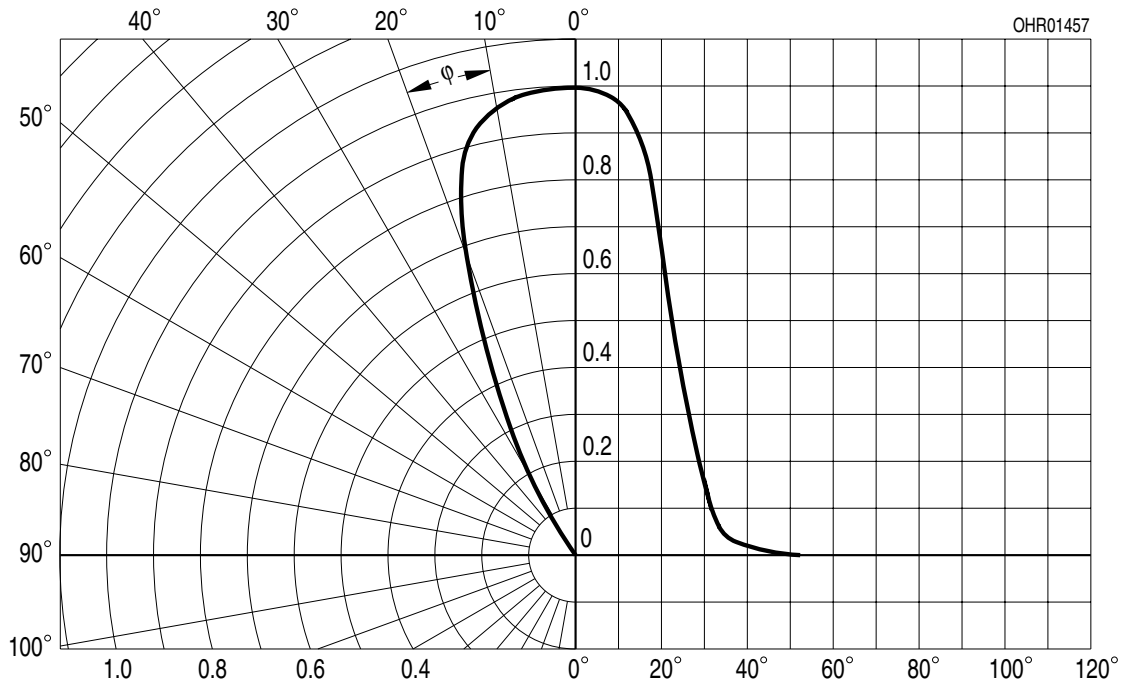

**Forward current** 4), 5)

$I_F = f(V_F)$ ; single pulse;  $t_p = 100 \mu s$

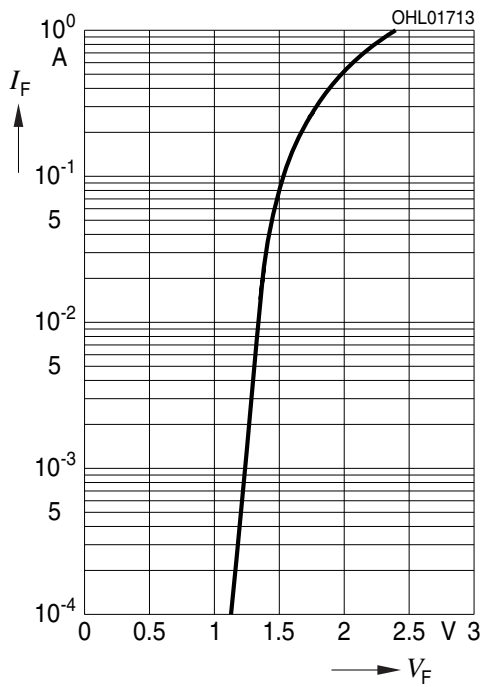

**Relative Radiant Intensity** 4), 5)

$I_e/I_e(100mA) = f(I_F)$ ; single pulse;  $t_p = 25 \mu s$

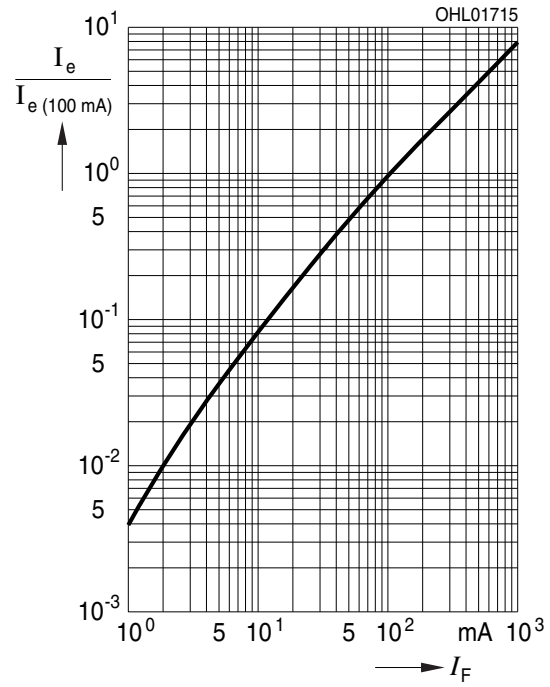

Discontinued

### Max. Permissible Forward Current

$I_{F,max} = f(T_A)$ ;  $R_{th,ja} = 450\text{K/W}$ ; single pulse

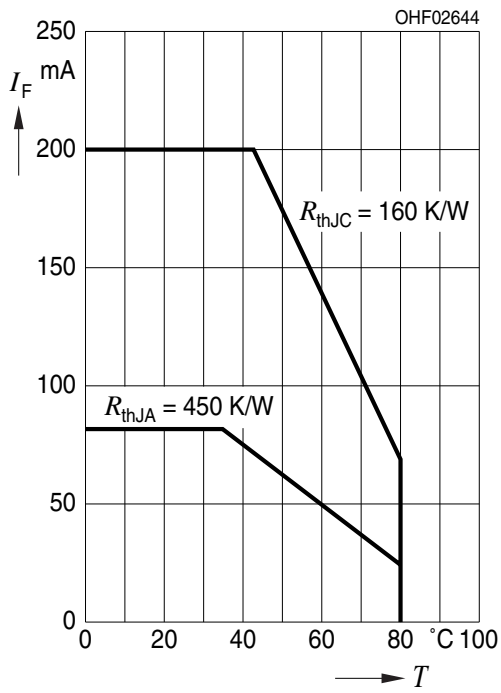

### Permissible Pulse Handling Capability

$I_F = f(t_p)$ ; duty cycle  $D = \text{parameter}$ ;  $T_A = 25^\circ\text{C}$

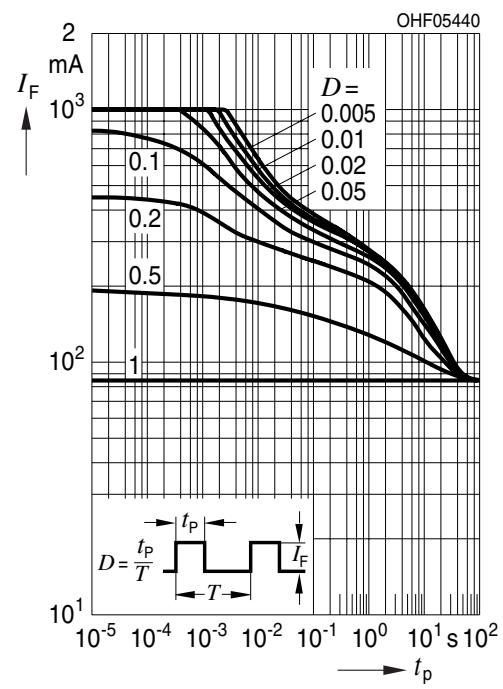

## Dimensional Drawing <sup>6)</sup>

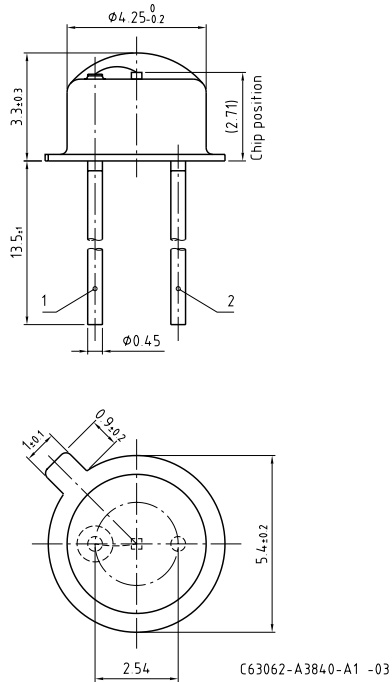

## Further Information

Approximate Weight: 180.0 mg

Pin	Description
1	Cathode
2	Anode

### Recommended Solder Pad <sup>6)</sup>

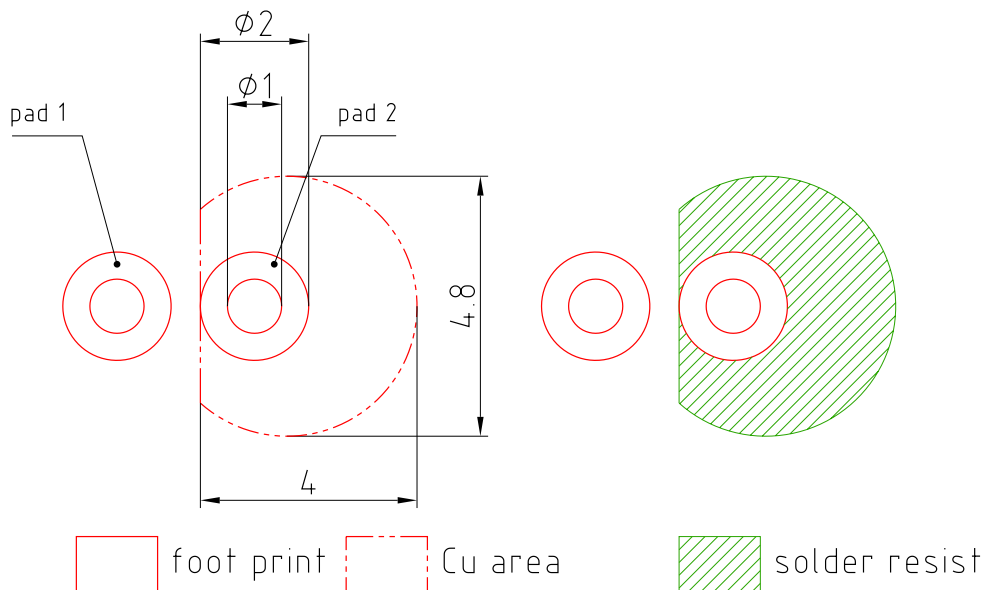

E062.3010.188-01

Pad 1: cathode



# TTW Soldering

IEC-61760-1 TTW

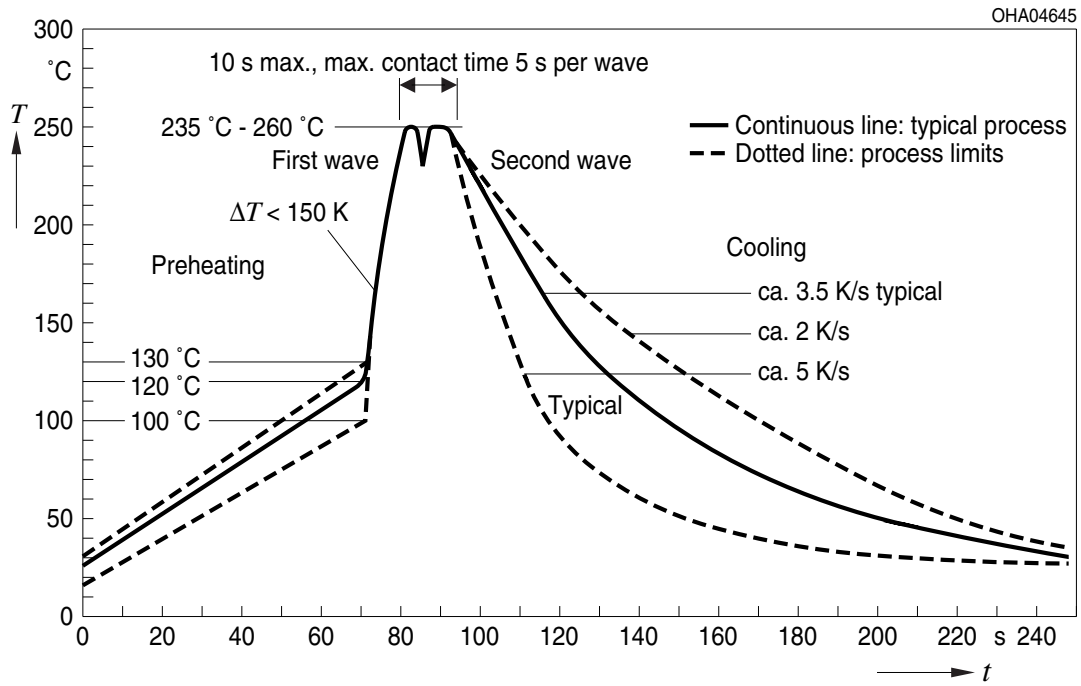

Discontinued

---

## Notes

The evaluation of eye safety occurs according to the standard IEC 62471:2006 (photo biological safety of lamps and lamp systems). Within the risk grouping system of this IEC standard, the device specified in this data sheet falls into the class **exempt group (exposure time 10000 s)**. Under real circumstances (for exposure time, conditions of the eye pupils, observation distance), it is assumed that no endangerment to the eye exists from these devices. As a matter of principle, however, it should be mentioned that intense light sources have a high secondary exposure potential due to their blinding effect. When looking at bright light sources (e.g. headlights), temporary reduction in visual acuity and afterimages can occur, leading to irritation, annoyance, visual impairment, and even accidents, depending on the situation.

Subcomponents of this device contain, in addition to other substances, metal filled materials including silver. Metal filled materials can be affected by environments that contain traces of aggressive substances. Therefore, we recommend that customers minimize device exposure to aggressive substances during storage, production, and use. Devices that showed visible discoloration when tested using the described tests above did show no performance deviations within failure limits during the stated test duration. Respective failure limits are described in the IEC60810.

For further application related information please visit [www.osram-os.com/appnotes](http://www.osram-os.com/appnotes)

## Disclaimer

### Attention please!

The information describes the type of component and shall not be considered as assured characteristics. Terms of delivery and rights to change design reserved. Due to technical requirements components may contain dangerous substances.

For information on the types in question please contact our Sales Organization.

If printed or downloaded, please find the latest version on the OSRAM OS website.

### Packing

Please use the recycling operators known to you. We can also help you – get in touch with your nearest sales office. By agreement we will take packing material back, if it is sorted. You must bear the costs of transport. For packing material that is returned to us unsorted or which we are not obliged to accept, we shall have to invoice you for any costs incurred.

### Product and functional safety devices/applications or medical devices/applications

OSRAM OS components are not developed, constructed or tested for the application as safety relevant component or for the application in medical devices.

OSRAM OS products are not qualified at module and system level for such application.

In case buyer – or customer supplied by buyer – considers using OSRAM OS components in product safety devices/applications or medical devices/applications, buyer and/or customer has to inform the local sales partner of OSRAM OS immediately and OSRAM OS and buyer and /or customer will analyze and coordinate the customer-specific request between OSRAM OS and buyer and/or customer.

## Glossary

- 1) **Radiant intensity:** Measured at a solid angle of  $\Omega = 0.01$  sr
- 2) **Reverse Operation:** Reverse Operation of 10 hours is permissible in total. Continuous reverse operation is not allowed.
- 3) **Total radiant flux:** Measured with integrating sphere.
- 4) **Typical Values:** Due to the special conditions of the manufacturing processes of semiconductor devices, the typical data or calculated correlations of technical parameters can only reflect statistical figures. These do not necessarily correspond to the actual parameters of each single product, which could differ from the typical data and calculated correlations or the typical characteristic line. If requested, e.g. because of technical improvements, these typ. data will be changed without any further notice.
- 5) **Testing temperature:** TA = 25°C (unless otherwise specified)
- 6) **Tolerance of Measure:** Unless otherwise noted in drawing, tolerances are specified with  $\pm 0.1$  and dimensions are specified in mm.

## Revision History

Version	Date	Change
1.6	2019-07-15	Discontinued

---

**Published by OSRAM Opto Semiconductors GmbH** EU RoHS and China RoHS compliant product  
**Leibnizstraße 4, D-93055 Regensburg**  
**www.osram-os.com © All Rights Reserved.**



此产品符合欧盟 RoHS 指令的要求；  
按照中国的相关法规和标准，不含有毒有害物质或元素。